

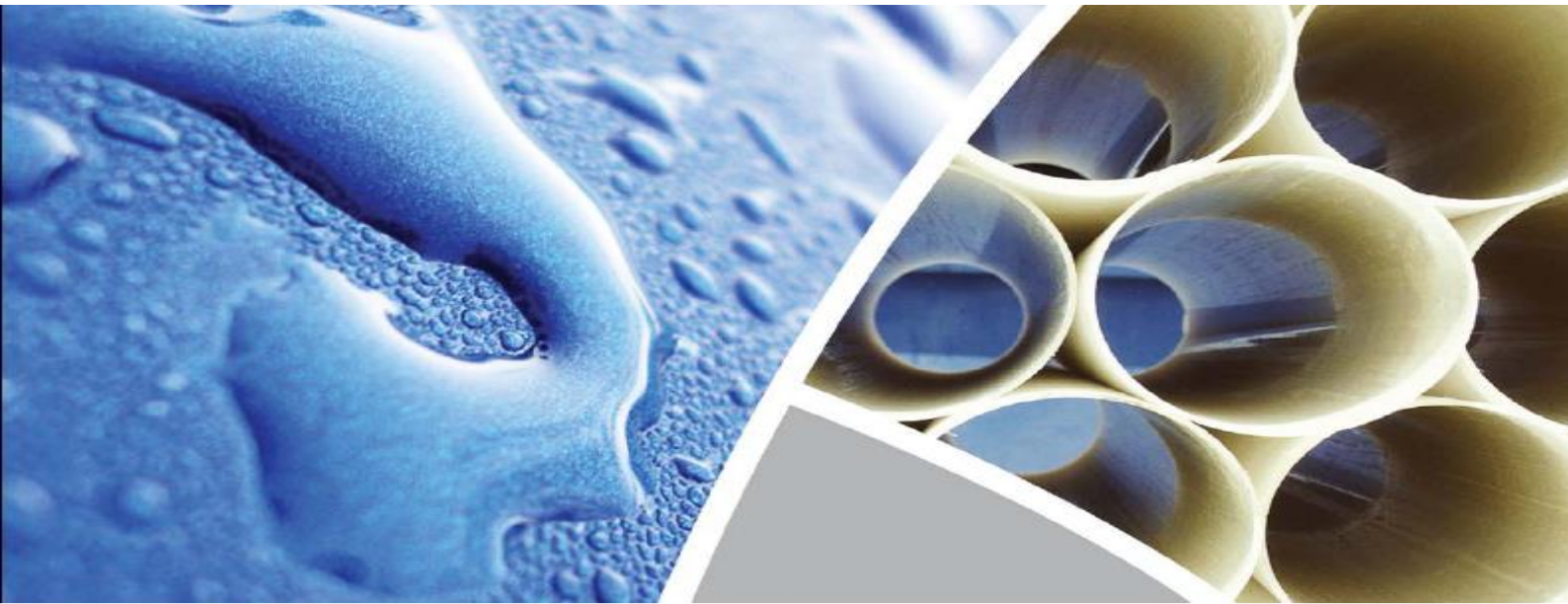

ADVANCED PIPING SOLUTIONS
حلول الأنابيب المتطورة

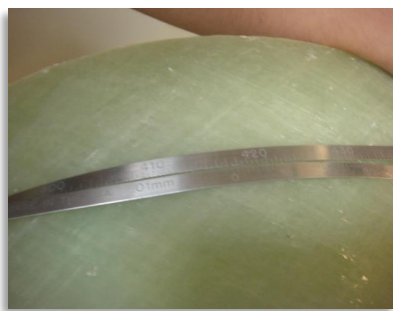

Helical Winded GRP/ GRV



INDEX

- 1. INTRODUCTION**
 - 2. APPLICATIONS**
 - 3. APPLICABLE STANDARDS**
 - 4. BENEFITS**
 - 5. MATERIALS**
 - 6. PRODUCTION PROCESS**
 - 7. QUALITY ASSURANCE**
 - 8. PIPE PRODUCT RANGE**
 - 9. FITTINGS**
 - 10. INSTALLATION**
- APPENDICES**

1. INTRODUCTION

Founded in 2007 Advanced Piping Solutions Previously Known as Arabian Company for Water Pipe Industry Ltd. (ACWAPIPE) has attained remarkable success in just a few years. The Company's immense vision enabled it to recognize the rapidly growing demand for Fiber Glass piping in power and water sectors of **Saudi Arabia**.

Thus the company has set up manufacturing facilities for pipes and it has two plants; one is located in the Eastern Province of Saudi Arabia in Dammam, 2nd Industrial Area for producing GRP (Glass-Reinforced Polyester) and GRE (Glass-Reinforced Epoxy) pipes at an annual capacity of 30,000 tons for different sizes and applications. The second production facility is located on the western province of Saudi Arabia in Rabigh for the manufacturing of Concrete pipes with an annual capacity of 150,000 tons and GRP pipe with an annual capacity of 12,000 tons of different sizes and applications.

Advanced Piping Solutions produces Helical Winded Pipes in diameters ranging from 25 to 1200 mm, pressures from 6 to 32 BarG and these pipes are available in mechanical and laminated jointing systems.

2. APPLICATIONS

Helical Winded products are designed for use in normal to aggressive environments with a wide operational temperature range. The following are standard applications for Helical Winded products:

Industrial Plants:

- Chemical processing plants
- Fertilizer plants
- Food processing industries
- Paper and textile industries
- Petrochemical plants
- Sanitary and industrial sewerage plants
- Refinery, Oil and Gas

Utilities:

- Fire Fighting
- Water desalination plants
- RO plants
- Public water supply

Consult the manufacturer for pipes intended to handle heavy industrial wastes, abrasive slurries, toxic chemicals, hazardous fluids or those for above ground or higher temperature services.

2.1 Factory Mutual (FM) Approved

Advanced Piping Solutions Helical Winded GRP pipes & fittings are available from 4" to 24" (100 to 600mm) with approval from Factory Mutual (FM) class FM 1614 up to 16 Bar (232 psi) pressure rating.



3. APPLICABLE STANDARDS

To ensure that Helical wound fiberglass pipes and fittings conform to universal specifications, exhibit the highest quality, performance, they are manufactured in accordance with the following international Standards and others

- AWWA C950 – AWWA Standard for Fiberglass Pressure Pipe
- AWWA M45 – Fiberglass Pipe Design
- ASTM D 3517 – Standard Specification for "Fiberglass (Glass Fiber Reinforced Thermosetting Resin) pressure pipe"
- ASTM D 3754 – Standard Specification for "Fiberglass (Glass Fiber Reinforced Thermosetting Resin) sewer and industrial pressure pipe"
- SAMSS 034 – RTR (Fiberglass) Pressure Pipe and Fittings
- SAMSS 029 – RTR (Fiberglass) Sewer Pipe and Fittings for Gravity Flow
- FM 1614 – Approval Standard for Fiber Reinforced Composite (FRC) Pipe and Fittings for Underground Fire Protection Service

4. BENEFITS

Advanced Piping Solutions manufactures of Helical Winded Pipes and fittings using the Discontinuous Filament Winding (**DFW**) process. The products are superior to other conventional piping materials in many applications, and when correctly specified offer substantial benefits.

4.1 Corrosion Resistant

Epoxy resins offer superior corrosion performance to those made with polyester resins in many applications (although some chemical duties are served better with polyester or vinyl ester resins) and epoxies are better in handling higher operating temperatures than most other resins which are used to filament winding.

4.2 Light weight and Long Pipe Sections

Helical wound fiberglass pipe is about one fourth of the weight of a DI pipe and one tenth of Concrete pipe by weight for comparable duty applications, thus offering substantially reduced transport, handling and installation equipment costs. The standard pipe length is 3, 6 or 12 meters depending on the diameter range.

4.3 Extremely Smooth Pipe Interior Surface

Helical wound fiberglass pipes have very smooth bore compare to steel pipes which reduces fluid flow frictional losses thereby reducing the required pumping power and thus the pumping cost. The lifespan of pumps and other inline equipments are extended due to rust free flow in Helical wound fiberglass pipes. Unlike most metallic pipe systems, Helical wound fiberglass pipes do not corrode or suffer from scale build up on the inside surfaces and thus retain almost unchanged flow characteristics over their operational life. The Hazen William Coefficient used is 150 for Helical wound

fiberglass pipes due to extremely smooth pipe internal surface; on the other hand steel pipe has a Hazen William Coefficient 120 when new and 65 when used. A minor coating of slime may build up on the bore of Helical wended fiberglass pipe but this does not materially reduce the flow characteristics.

5. MATERIALS

Helical wended fiberglass pipes derive strength from the raw materials used. The mechanical strength of pipe and fittings depend upon the type, amount and positioning of glass fibers, while the desired chemical and thermal properties of the product are based upon the resin used.

6. PRODUCTION PROCESS

The pipes are produced by discontinuous balanced helical filament winding to maximize the benefits from the fiber orientation with precisely aligned fibers. Fiber placement is accurately achieved by using a computer controlled system that integrates the two axes of motion (rotation of the mandrel and longitudinal traverse of the glass carrier) to ensure that a balanced covering of fiber is achieved over the pipe surface with the fibers precisely aligned at the required helical angle. The fiber spacing is such that complete coverage of the mandrel surface is achieved with great accuracy.

6.1 Discontinuous Filament Winding (DFW) Process

The process essentially consists of rotating a mandrel and applying continuous fibers in a balanced helical pattern, at a specified winding angle approximately 55 degrees, with simultaneous resin impregnation.

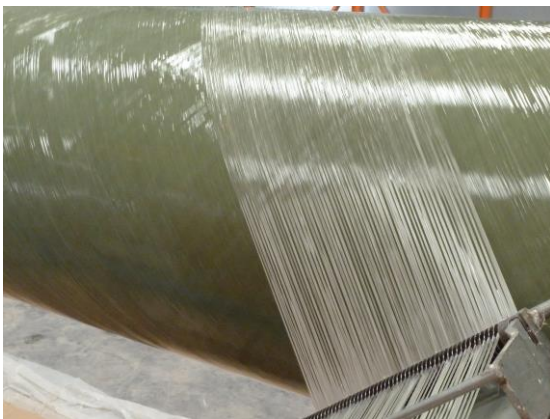

6.2 Pipe Calibration

Pipe is calibrated based on the joint configuration and dimensional requirement.

- Fix the pipe and align both the ends on the calibration unit
- A rough manual cut is advisable for easy insertion of the pipe on the machine.
- Select the correct calibrating tool and mount on the calibration machine.
- Measure the pipe and mark precisely based on the finished product dimensions as per the product and engineering data.

- The machining tools are manufactured based on product joint dimensions, therefore the calibrated end will have the required dimensions, however the calibration shall be made within the tolerance.
- Measure the calibrated end before the product is released from the machine.



6.3 Pipe Testing

It is mandatory to hydrostatically test the produced pipes based on Quality Control procedure.

- Start the pressure pump and gradually increase the pressure up to the required test pressure and hold it to the desired holding time
- Inspect the pipe carefully for any leakage from the body of the pipe. If no leakage is found, the test is completed after the holding time. Release the pressure slowly and carefully until the pressure reaches to 0 Bar G. Release the testing heads slowly to drain the water from inside the pipe and move the pipe out from the machine.

7. QUALITY ASSURANCE

Each individual pipe and sleeve undergoes a rigorous series of tests which include visual, hydraulic, stiffness, hoop tensile, axial tensile and other tests in accordance with ASTM, AWWA, ISO and other international material testing standards. The Advanced Piping Solutions quality control department implements a strict screening process to ensure that only products passing the highest quality standards reach our clients.



7.1. Quality Control Tests

Quality is of prime importance in the manufacture of Helical wound fiberglass pipes. As soon as a single pipe is pulled off the mandrel, it undergoes the following tests, among others, to determine the level of quality for each pipe product.

Each individual pipe is mounted on a hydraulic testing machine, filled with water and pressurized for 1.5 to 2.0 times the rated pressure based on standards requirement. The pressure gauges are monitored for between 30 seconds to 5 minutes, without pressure drop, as required by the relevant test specification.

Samples from each batch is taken to be tested for both axial and circumferential (hoop) tensile strengths. The specimens are loaded-to-break point using UTM and split disk respectively for axial and hoop tensile strength.

These data are used to determine that axial and hoop tensile strengths of the batch have passed and exceeded the mandatory international standards requirements.

Type of Tests and Inspections	Testing Frequency	Standard Reference
Wall thickness	Each pipe	ASTM D3567
Outside diameter, spigot end	Each pipe	AWWA C950
Length	Each pipe	ASTM D3567
Visual inspection	Each pipe	ASTM D 2563
Hydrostatic pressure	Each pipe	ASTM D1599
Indentation hardness	Each pipe	ASTM D 2583
Pipe stiffness	Per batch	ASTM D2412
Axial tensile strength	Per batch	ASTM D 638
Hoop tensile strength	Per batch	ASTM D 2290
Loss on Ignition (LOI)	Per batch	ASTM D 2584

Table 2: Type of Tests and Inspections



Raw materials are likewise tested before being used in the manufacture of Helical wound fiberglass products. These tests will typically include viscosity and gel-times for resin types. Glass reinforcing fibers also undergo several tests including moisture content and checks on sizing content. These tests ensure that the pipe materials comply with the specifications as stated.

7.2. QUALIFICATION TESTS

The tests indicated below are generally relevant to Helical wound fiberglass pipes systems.

7.2.1 Hydrostatic Design Basis (HDB)

One of the important qualification tests is the establishment of the Hydrostatic Design Basis.

This test is carried out in accordance with ASTM D2992 procedure B and requires hydrostatic testing to failure (leakage of several pipe samples at a variety of very high constant pressure (strain) levels. These must result in failures varying from within minutes to at least 10,000 hours. The resulting data is evaluated on a log-log basis for pressure (hoop tensile strain) vs. time to failure and then extrapolated to 50 years.

The extrapolated failure pressure (strain) at 50 years referred to as the hydrostatic design basis (strain) or HDB must be at least 1.8 times the pressure (strain) caused by the rated pressure class.

In other words the design criterion requires that the average pipe shall be capable of withstanding a constant pressure of 1.8 times the maximum operating condition for 50 years. This qualification test helps assure the long term performance of the pipe in pressure service.

7.2.2 Joint Testing

The third important qualification test is conducted on joint prototypes for elastomeric gasket sealed couplings. This is a severe test carried out in accordance with ASTM D4161. It incorporates some of the most stringent joint performance requirements in the piping industry for pipe of any material within the pressure and size ranges indicated and requires these flexible joints to withstand hydrostatic testing in configurations that simulate very severe in use conditions. Test pressures used are twice those rated for the normal design pressure of the pipe. Joint configurations include straight alignment at test pressure, maximum angular misalignment at test pressure, and pressure retention capability with applied shear loading.

8. PIPE PRODUCT RANGE

The Helical wound fiberglass pipes are sized in accordance with international standards. The pipe length available for DN 25 to 250 mm is 6 m and for DN 300 to 1200 mm is 12 m.

9. FITTINGS

Helical winded fiberglass fittings are also available in numerous types. Details of the standard fittings and their joints are mentioned in **Appendix B**.

Advanced Piping Solutions can also produce non-standard fittings in all the sizes and different combinations based on the customer requirements. Some of the typical fittings offered are:



- Elbows- Different diameters and angles both swept or mitered depending upon diameters and pressure ratings.
- Tees – Equal or Unequal Tees of different diameters
- Reducers – Eccentric or Concentric of various diameters
- Flanges – Flanges of various diameters drilled to International Standard as per requirements. Flanges may be offered as full face type or stub flange type with backing rings.
- Other Fittings- End Caps, Puddle Flanges, Dummy Supports or combination of any of the above.

10. INSTALLATION

Consult Advanced Piping Solutions for Underground and Aboveground installation of helical wind fiberglass piping. Advanced Piping Solutions will provide the project specific installation instruction guide.



APPENDIX A: HELICAL WINDED FIBERGLASS PIPES

Advanced Piping Solutions Helical wound fiberglass pipes for underground application can be supplied in the following nominal diameters (mm) for restrain joint system.

DN	ID +/- 2 mm	PN 6 Bar			PN 10 Bar			PN 16 Bar		
		Tp +/- 0.5 mm	OD +/- 2 mm	Weight (Kg/m)	Tp +/- 0.5 mm	OD +/- 2 mm	Weight (Kg/m)	Tp +/- 0.5 mm	OD +/- 2 mm	Weight (Kg/m)
25	25	3.20	31.4	1	3.20	31.40	1	3.20	31.4	1
40	40	3.20	46.4	1	3.20	46.40	1	3.20	46.4	1
50	50	3.20	56.4	1.5	3.20	56.40	1.5	3.20	56.4	1.5
80	80	3.20	86.4	2	3.20	86.40	2	3.20	86.4	2
100	100	4.10	108.2	2.5	4.10	108.20	2.5	4.10	108.2	2.5
150	150	4.50	159	3.5	4.50	159.00	3.5	4.70	159.4	3.5
200	200	4.50	209	5.5	4.50	209.00	5.5	5.30	210.6	5.5
250	250	4.50	259	6.5	4.50	259.00	6.5	5.90	261.8	6.5
300	300	4.80	309.6	8	5.20	310.40	8	6.40	312.8	8
350	350	4.80	359.6	11	5.20	360.40	11	7.00	364	11
400	400	5.20	410.4	15	5.60	411.20	15	7.40	414.8	15
450	450	5.40	460.8	17	6.00	462.00	17	7.80	465.6	17
500	500	6.00	512	20	6.40	512.80	20	8.30	516.6	20
600	600	7.20	614.4	29	7.20	614.40	29	9.20	618.4	29

For larger diameters up to DN1200, aboveground application please consult Advanced Piping Solutions for project specific design thickness and diameters.

APPENDIX B: HELICAL WINDED FIBERGLASS PIPE JOINTS

LAMINATION JOINT

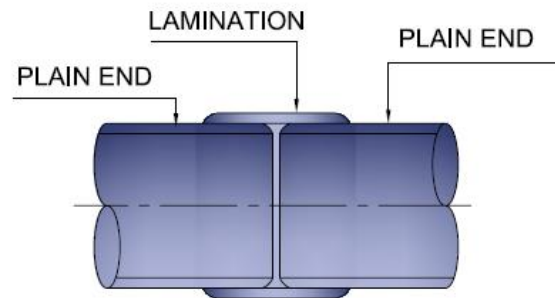

This is a restrained joint system used for joining plain end pipes which consists of overlapping layers of fiberglass reinforcement thoroughly impregnated with the resin to achieve the specified width and thickness. It provides continuity in both hoop and axial directions. It is generally preferred for field adjustments and repair work where no other joint systems can be used. For small diameters below 600 mm only external lamination is provided while for diameters above 600 mm both internal and external lamination is provided.

FLANGE JOINT

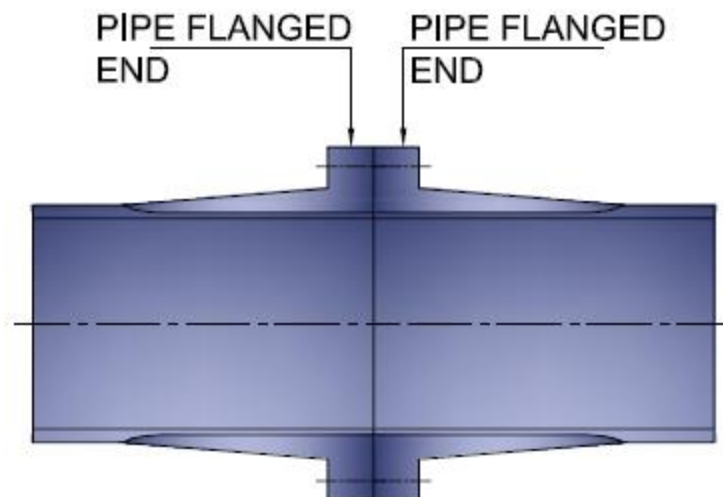

This is a restrained joint system which is normally used for joining fiber glass pipes with existing steel pipes and accessories like valves, pumps etc. It is also used where the installation has to be disassembled at a later stage. The hydraulic sealing between the flanges is accomplished with an elastomeric gasket, which may be flat type or O-ring type depending on the specifications.

APPENDIX C: HELICAL WINDED FIBERGLASS FITTINGS

ELBOWS

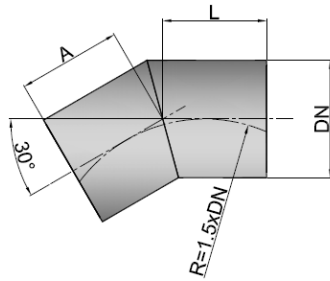

30° ELBOW, 1-MITER

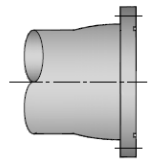

FLANGE END

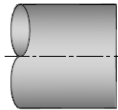

PLAIN END

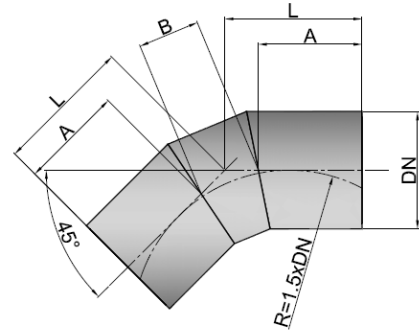

45° ELBOW, 2-MITER

DN(mm)	A(mm)	L(mm)
25	350	350
40	350	350
50	350	350
80	350	350
100	350	350
150	350	350
200	350	350
250	350	350
300	350	350
350	350	350
400	400	400
450	400	400
500	450	450
600	500	500
700	550	550
800	600	600
900	650	650
1000	650	650
1200	700	700

DN(mm)	A(mm)	B(mm)	L(mm)
25	350	15	358
40	350	24	363
50	350	30	366
80	400	48	426
100	400	60	432
150	400	90	448
200	400	119	465
250	400	149	481
300	400	179	497
350	400	209	513
400	400	239	529
450	400	269	545
500	450	298	611
600	500	358	694
700	550	418	776
800	600	477	858
900	650	537	941
1000	700	597	1023
1200	800	716	1188

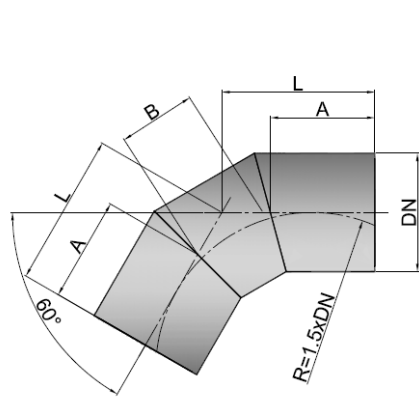

60° ELBOW, 2-MITER

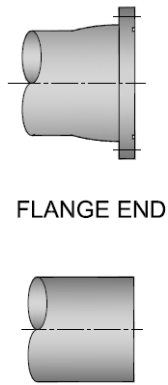

PLAIN END

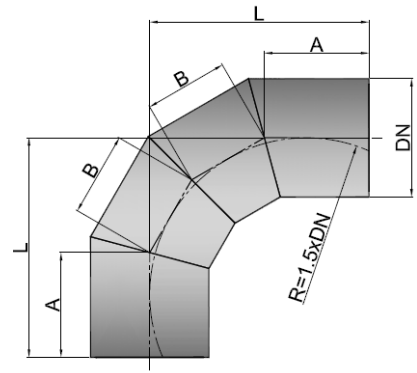

90° ELBOW, 3-MITER

DN(mm)	A(mm)	B(mm)	L(mm)
25	350	20	362
40	350	32	369
50	350	40	373
80	400	64	437
100	400	81	446
150	400	121	470
200	400	161	493
250	400	201	516
300	400	241	539
350	400	281	562
400	400	322	586
450	400	362	609
500	450	402	682
600	500	482	778
700	550	563	875
800	600	643	971
900	650	723	1068
1000	700	804	1164
1200	800	965	1357

DN(mm)	A(mm)	B(mm)	L(mm)
25	350	20	377
40	350	32	394
50	350	40	405
80	400	64	488
100	400	81	510
150	400	121	565
200	400	161	620
250	400	201	675
300	400	241	729
350	400	281	784
400	400	322	839
450	400	362	894
500	450	402	999
600	500	482	1159
700	550	563	1319
800	600	643	1478
900	650	723	1638
1000	700	804	1798
1200	800	965	2118

TEES

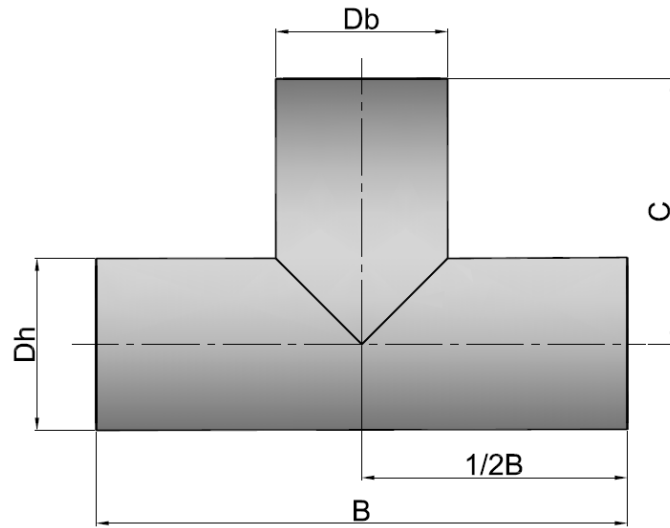

$D_b \geq 0.5 D_h$

DN(mm)	B(mm)	C(mm)
25	500	300
40	500	300
50	600	300
80	800	500
100	900	500
150	1100	500
200	1200	600
250	1250	625
300	1300	650
350	1400	700
400	1400	700
450	1500	750
500	1600	800
600	1800	900
700	2050	1025
800	2300	1150
900	2550	1275
1000	2800	1400
1200	3300	1650

$D_b \leq 0.5 D_h$

DN(mm)	B(mm)	C(mm)
25	500	300
40	500	300
50	600	300
80	800	500
100	900	500
150	1100	500
200	1200	600
250	1250	625
300	1300	650
350	1000	560
400	1000	570
450	1050	650
500	1080	670
600	1220	760
700	1350	850
800	1480	940
900	1650	1030
1000	1750	1130
1200	2020	1310

REDUCERS

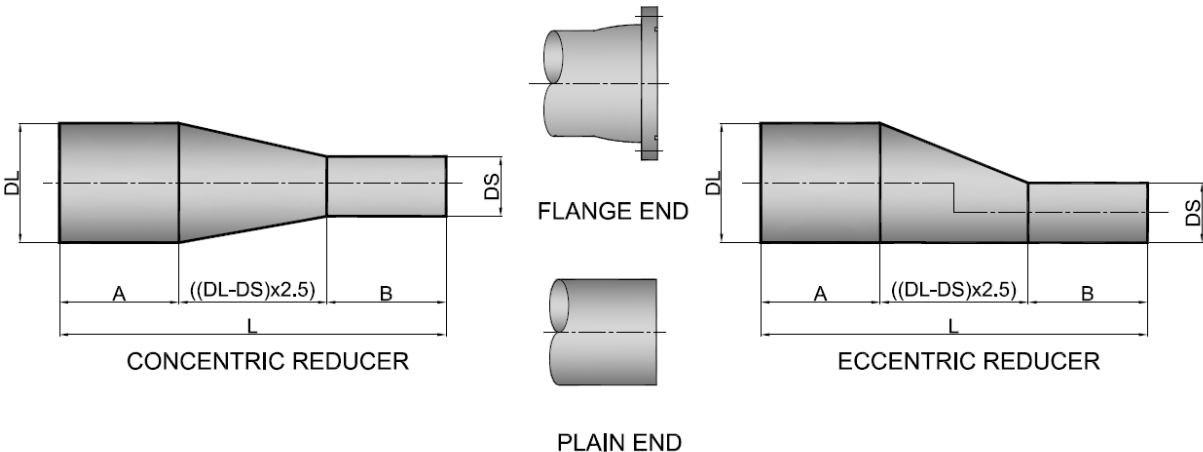



ADVANCED PIPING SOLUTIONS
حلول الأنابيب المتطورة



For further information and inquiries about our products, please contact us at: Tel. 920012040

www.advancedpiping.com.sa